

FX2 Series

Edge-lit Flat Diffuse Lights | Product Datasheet

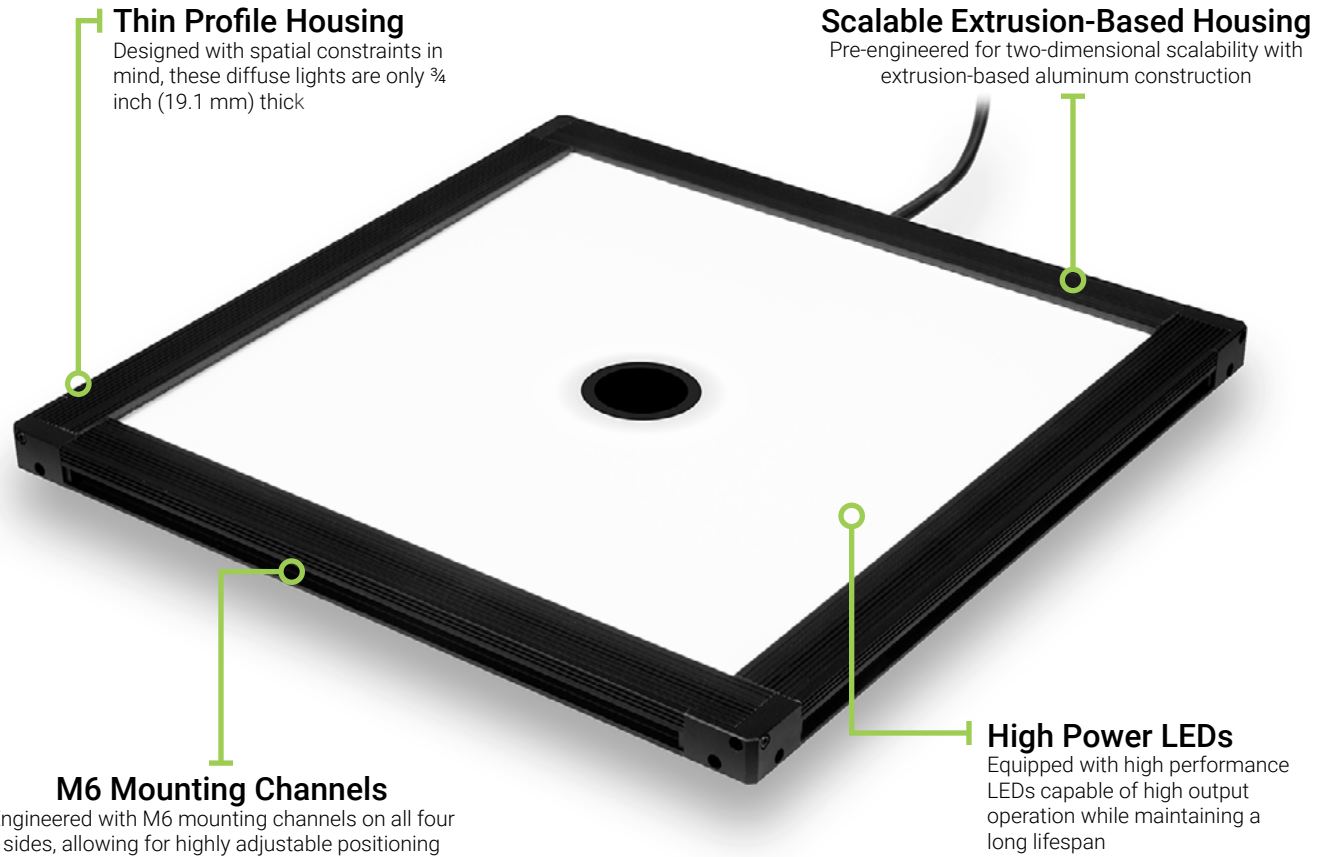

FX2 Series Description

The FX2 Series of edge-lit flat diffuse lights provides a highly diffuse source of illumination within a thin, thermally efficient housing.

The FX2 differs from back-lit diffuse designs in that the LEDs are positioned in the frame, rather than behind the emitting window. This side-lit geometry enables a scalable planar design with highly uniform output at longer working distances. The FX2 also allows for configuration with polarization to reduce glare on reflective surfaces, while a central view port size can be specified for imaging through the light in select front lighting applications.

As a diffuse front light, this product is useful for applications involving reflective packaging, printed text inspection, and other



High Intensity



Scalable Design



11 Wavelengths Available



Polarization Optional



2 Weeks BTO Lead Times Typical

General Information

General Specifications

Category	Specification	Detail			
Optical	Available Wavelengths	White, 455 nm, 470 nm, 505 nm, 530 nm, 590 nm, 625 nm, 660 nm, 730 nm, 850 nm, 940 nm			
	Available Lensing	No Lenses			
	Available Light Conditioning	Polarization			
Electrical	Power Consumption Info	See Power Requirements on Page 8			
	Cable Info	80" -0/+6" Long (2m -0/+150 mm), -105 °C Rated, Foil Shield w/ Drain			
Mechanical	Sizing Info	Standard	Length	1.91 in (48.5 mm) to 23.56 in (598.5 mm)	See Page 7 for More Details
		Width	1.91 in (48.5 mm) to 23.56 in (598.5 mm)		
		Height	0.75" (19.1 mm)		
	Viewport Size	1/4" increments from 1/4" to 3"			
Thermal	Weight Info (Standard)	4.73 lb (2.14 kg) per 300 mm x 300 mm Unit			
	Mounting Info	M6 Mounting Nut Channel			
	Material Info	Anodized Aluminum Housing, Acrylic Window, Acrylic Strain Relief, PVC Cable Jacket, Steel Back Oxide and Zinc Plated Steel Fasteners			
	Operating Case Temperatures	25 °C to 60 °C			
Certification	Operating Ambient Temperatures	0 °C to 35 °C			
	Compliance	CE, RoHS, IEC 62471			
	IP Rating	IP40			
	Lumen Maintenance - White Only	L70 (50,000 Hours)			

General Information - Continued

Part Number Key

Model	-	Emitting Length (in)	Emitting Width (in)	Hole Diameter	Peak Wavelength	Connector/Control	Light Conditioning Option	-	Alternative Connector
XXX	-	XXX	XXX	X	XXX	XXX	X	-	XXX
FX2		up to 600 mm	up to 400 mm	A - 6 mm (.25")	455 (royal-blue)	C1	P (Polarization) ^{2 3}		M12 ¹
				B - 12 mm (.5")	470 (blue)	C5			M8 ¹
				C - 18 mm (.75")	505 (cyan)	24			
				D - 25 mm (1") Standard	530 (green)	IC			
				E - 31 mm (1.25")	590 (amber)	I3			
				F - 37 mm (1.5")	625 (red-orange)	I3S			
				G - 43 mm (1.75")	660 (red)				
				H - 50 mm (2")	730 (IR)				
				I - 56 mm (2.25")	850 (IR)				
				J - 62 mm (2.5")	940 (IR)				
				K - 68 mm (2.75")	WHI (white)				
				L - 75 mm (3")					
more information on page		10	10		5	11	6		13

Example Part Numbers:
FX2-600400K850C5-M12
FX2-400200D470C1

¹ Available with 24, IC, I3, I3S, and I4 only
² Maximum size of 400 mm x 400 mm
³ 455 (royal-blue) will reduce the life of the polarizer if selected

In Stock

Lead Times

Unavailable

Build-to-Order products ship within two weeks (typical).

Configurator

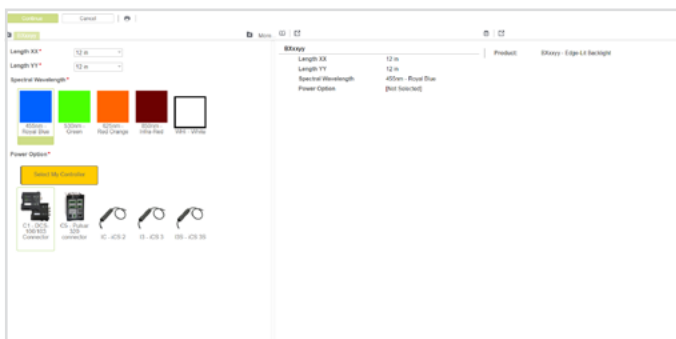

Need a build-to-order lighting solution in 4 weeks or less? Advanced Illumination's online configurator helps you tailor our FX2 Edge-lit Diffuse Backlights to your specific needs. For a guided configuration of the FX2 Series, visit our [online configurator](#) by navigating to the product's webpage and selecting the "Configure" button.

Optical Information

Intensity Characteristics

Intensity Distribution Image at 100 mm Working Distance

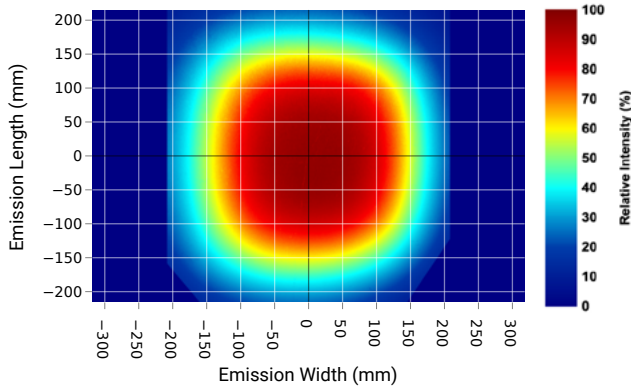

Intensity distribution sample image was taken with a 12-inch x 12-inch white FX2 unit.

Illuminance vs Working Distance

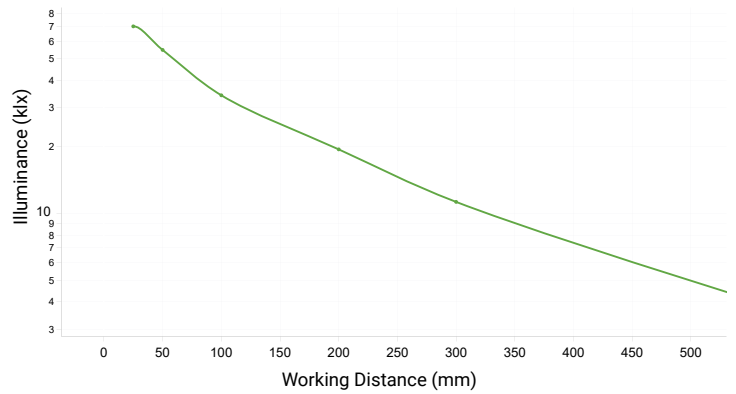

Illuminance data was collected using a 12-inch x 12-inch white FX2 unit.

FWHM vs Working Distance

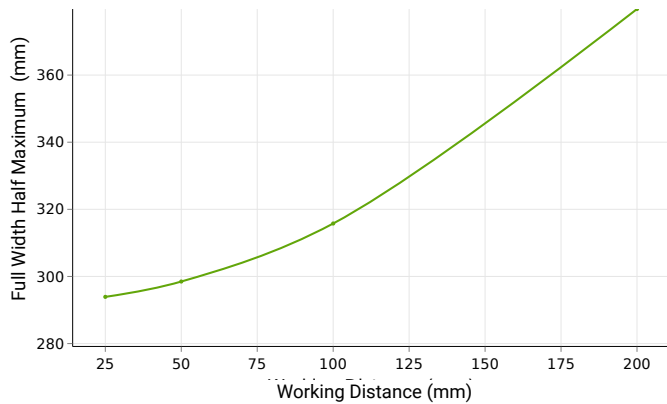

The FX2 provides highly diffuse illumination, ensuring uniformity within +/-10% at working distances greater than or equal to 50mm.

Full Width Half Maximum (FWHM) data collected using a 12-inch x 12-inch white Fx2 unit.

Continuous vs Strobe Intensity

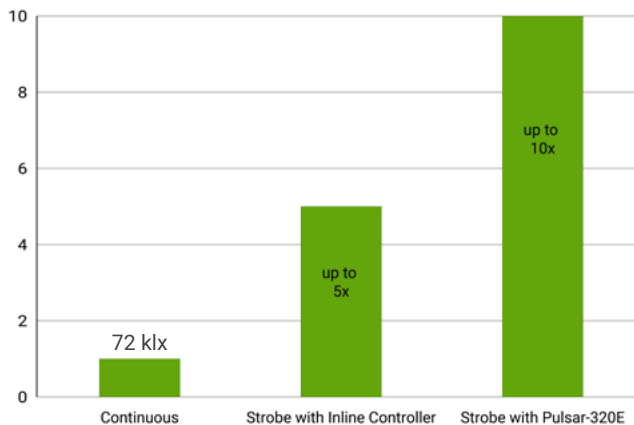

Under continuous operation, an 300 mm white FX2 unit will output a **maximum illuminance of 72 klx** and a **maximum irradiance of 229 W/m²** at the emitting surface. For applications that require higher output, the FX2 Series has been engineered to be overdrive strobe capable. When configured with AI's strobe enabled Inline Controller (I3, I3S, and I4), the FX2 is capable of outputting up-to 5X continuous levels. When configured with a C5 connector, compatible with AI's Pulsar 320E, a FX2 can be strobed up-to 10X continuous intensity levels.

Optical Information - Continued

White Spectral Profile

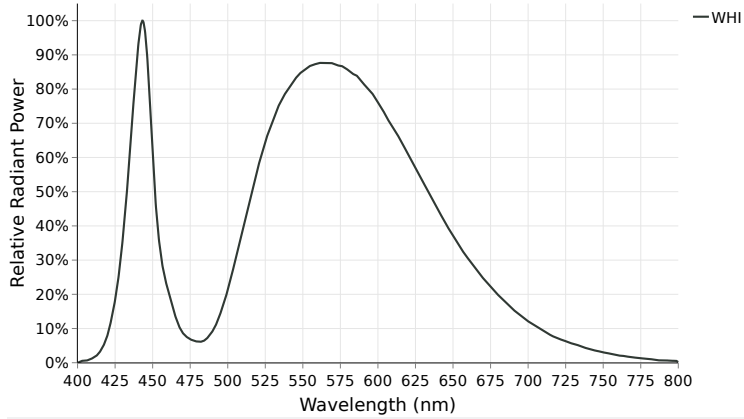

White LED illumination is the most commonly used machine vision lighting configuration. It is often the default choice when specific features of interest do not require color-based highlighting. However, **white LEDs can vary in color temperature between different lighting families, which can impact machine vision systems**, specifically when matching white light sources.

The FX2 Series white LEDs have a relatively neutral color correlated temperature (CCT) of **5500k**.

Visible Spectral Profiles

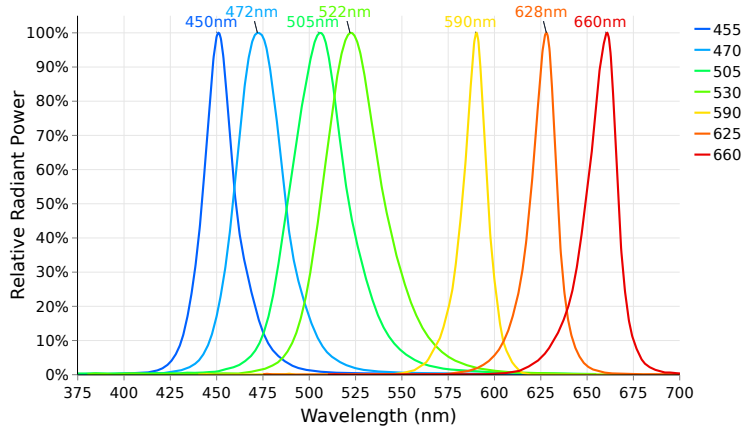

Visible color illumination consists of using wavelengths between 400-700 nm to either create or eliminate contrast on an inspection subject based on differences in a features color hue. When referring to a color wheel, simply remember the following: like colors reflect and brighten surfaces; conversely, opposing colors absorb and darken surfaces.

The FX2 Series is available in **455 nm, 472 nm, 505 nm, 522 nm, 530nm, 590 nm, 628 nm, 660 nm** configurations.

Non-Visible Spectral Profiles

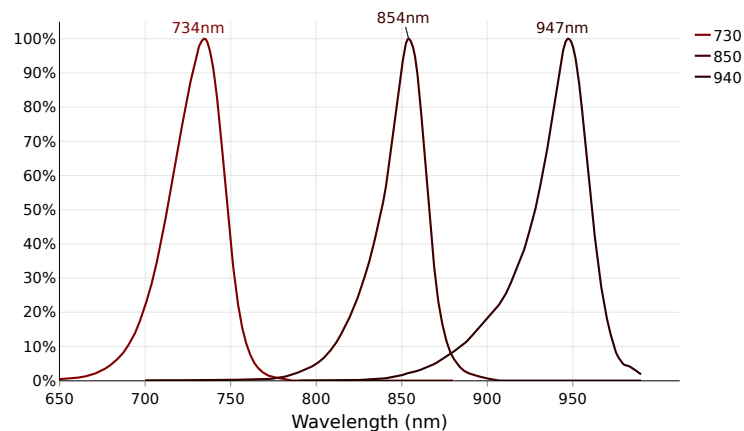

Near-infrared (NIR) imaging is a machine vision technique using longer wavelengths of 700-1000 nm to penetrate specific materials that are otherwise opaque to under the visible spectrum. When paired with a NIR camera, a NIR light can be ideal for applications such as fill level inspection, circuit board inspection, food safety inspection, and medical imaging.

The FX2 Series is available in an **730 nm, 850 nm, and 940 nm** configuration.

Disclaimer: The measurements provided above are for approximations only and may vary depending on the method of measurement and the specific configuration being measured.

Optical Information - Continued

Polarization Option Detail

Non-polarized



Polarized



Polarization has various applications, but it is most commonly used to reduce glare on specular surfaces when imaging reflective materials like plastic, metal, glass, or wet surfaces. By placing a linear polarizer over the light source and another over the camera lens, oriented perpendicularly, reflected light that causes glare can be selectively blocked. This allows for the observation of details that would otherwise be obscured by the reflection, such as printed text on packaging. However, since polarization inherently blocks some light, you may need to increase exposure to compensate for the reduced intensity, or consider alternative lighting geometries to lessen glare without polarization.

Photobiological Risk Factors

Group	Description	Affected Wavelengths
Exempt	No Photobiological Hazard	730 nm, 850 nm, 940 nm
Group 1	No Photobiological hazard under normal behavioral limitations	455 nm, 470 nm, 505 nm, 530 nm, 590 nm, 625 nm, 660 nm
Group 2	Does not pose a hazard due to aversion response to bright light or thermal discomfort	White

Cleaning Guidelines



To clean our light's optics, it is best to only clean when necessary. Dusting is always the first step in cleaning your optics. Wiping a dusty optic is like cleaning it with sandpaper. So always dust with a canned air duster or compressed and filtered air before wiping any optic. If the dusted optic has no visible stains after you dust it, then remember: "If it's not dirty, don't clean it." Avoid wiping optics when possible.

If dusting did not clean the lens or the lens has stains, use only de-ionized water and mild dish soap with a low lint cloth designed for optics to avoid damage to the optic by any harsh chemicals.

Polarizers, beam splitters and collimated films should never be wiped with any type of cloth or solvent, only use the air dusting method to clean these types of optics.

The aluminum housing can be wiped down when dusting is not a sufficient means to thoroughly clean.

Mechanical Information

Installation Drawings

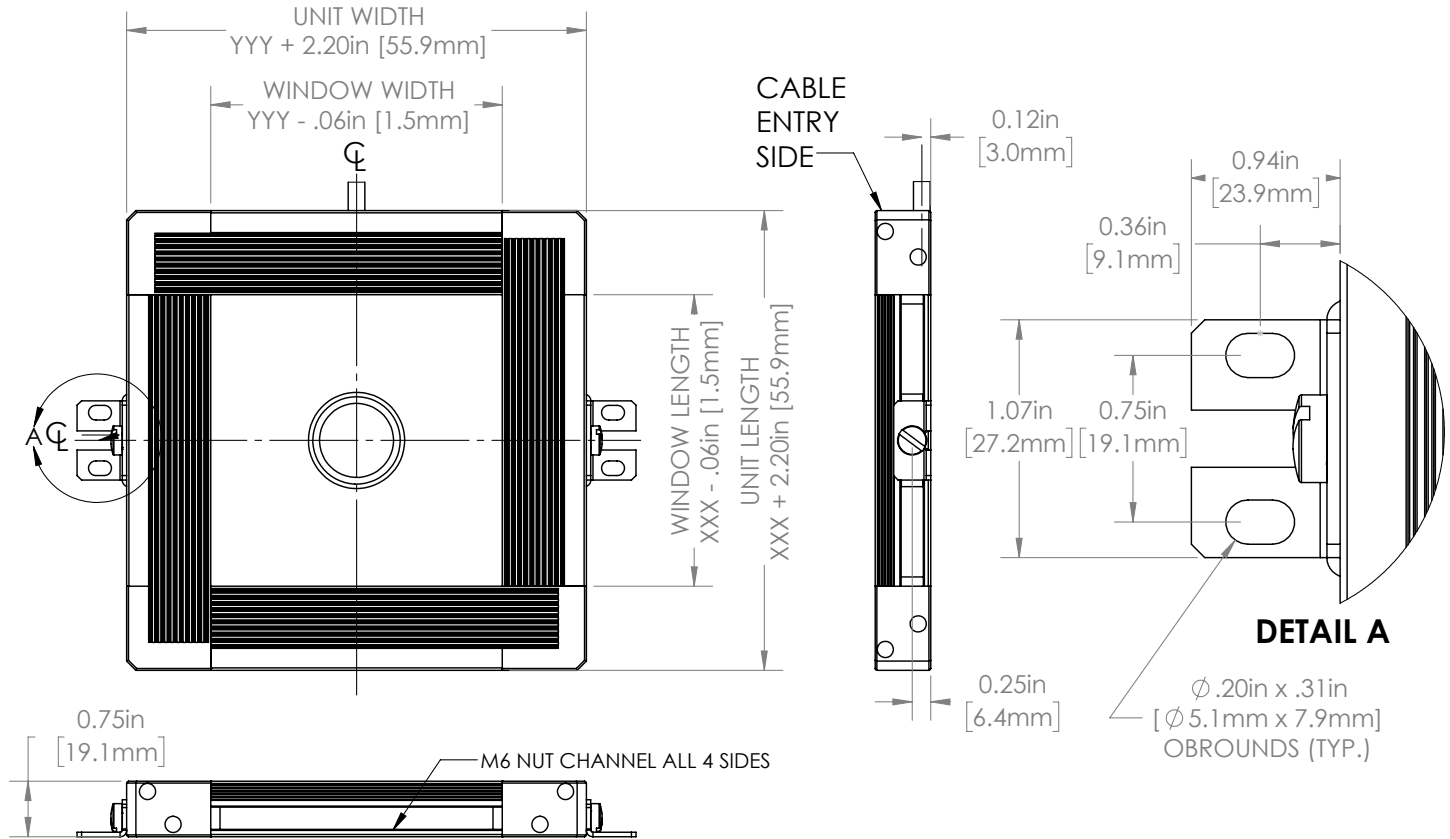

For full installation drawings and complete CAD models of this non-sealed configuration, please visit the [downloads](#) section of the product webpage.

Sizing Information

Our edge-lit flat diffuse lights are scalable to your specific sizing requirements.

We can manufacture our FX2 edge-lit flat diffuse light in 25 mm increments up to a 0.36m² emitting window, from a small 50 mm x 50 mm edge-lit panel to a large-format 600 mm x 600 mm edge-lit panel.

A central V-port (viewport) can also be specified to match your application, with hole diameters available in 1/4" increments from 1/4" to 3" (6–75 mm).

All FX2 light configurations are built-to-order with the majority shipping with only two week lead times.

For assistance configuring an edge-lit flat diffuse light to meet your specific needs, please visit our online configurator by selecting the "configure" button on our product page.

Electrical Information





Power Requirements

Current Required for Power Supply Sizing







Wavelengths	Configured with Voltage Drive (24)	Configured with Standard Controller (IC, I3, I3S, I4, C1, C5)
WHI	0.150 A per 25 mm of illuminated length (XX dimension)	0.250 A per 25 mm of illuminated length (XX dimension)
455 nm	0.150 A per 25 mm of illuminated length (XX dimension)	0.250 A per 25 mm of illuminated length (XX dimension)
505 nm	0.150 A per 25 mm of illuminated length (XX dimension)	0.250 A per 25 mm of illuminated length (XX dimension)
530 nm	0.150 A per 25 mm of illuminated length (XX dimension)	0.250 A per 25 mm of illuminated length (XX dimension)
590 nm	0.150 A per 25 mm of illuminated length (XX dimension)	0.167 A per 25 mm of illuminated length (XX dimension)
625 nm	0.150 A per 25 mm of illuminated length (XX dimension)	0.167 A per 25 mm of illuminated length (XX dimension)
660 nm	0.150 A per 25 mm of illuminated length (XX dimension)	0.167 A per 25 mm of illuminated length (XX dimension)
730 nm	0.150 A per 25 mm of illuminated length (XX dimension)	0.100 A per 25 mm of illuminated length (XX dimension)
850 nm	0.150 A per 25 mm of illuminated length (XX dimension)	0.100 A per 25 mm of illuminated length (XX dimension)
940 nm	0.150 A per 25 mm of illuminated length (XX dimension)	0.100 A per 25 mm of illuminated length (XX dimension)

Note: All Advanced Illumination lights and controllers are nominally powered by 24V DC unless otherwise noted. Strobe overdriving with controller based models may require more current and voltage overhead. The values above do not include background current draw from the controller (~100 mA total).

Control Options

Controller Image	Controller Details	Connector Image
	<p>DCS Single Output Controller - Compatible with C1 Configurations PN: DCS-100E</p> <p>The DCS-100E is a compact, din-rail mounted general-purpose external controller with one C1 output connector, wired with three channels. Capable of providing single channel control or multi-channel control for RGB compatible lights.</p> <p>Output Power: 90 W Max Continuous, 540 W Max Pulsed (Overdrive Strobe) Output Current: 4.5A Max Continuous, 15 A Max Pulsed I/Os: 3 External Trigger Inputs Interface: 10/100 Ethernet with Software and browser-based GUIs. SDKs are also available.</p> <p>For more information about our DCS-100E, please visit the controller product page.</p>	
	<p>DCS Triple Output Controller - Compatible with C1 Configurations PN: DCS-103E</p> <p>The DCS-103E is a din-rail mounted general-purpose multi-light controller with three C1 output connectors. Capable of driving three lights in sync or asynchronously.</p> <p>Output Power: 30 W Max Continuous / Output, 180 W Max Pulsed / Output Output Current: 1.5A Max Continuous / Output, 5 A Max Pulsed / Output I/Os: 3 External Trigger Inputs Interface: 10/100 Ethernet with Software and browser-based GUIs. SDKs are also available.</p> <p>For more information about our DCS-103E, please visit the controller product page.</p>	

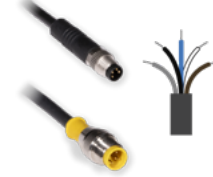
Electrical Information - Continued

Controller Image	Controller Details	Connector Image
	<p>Pulsar 320E High Current Controller - Compatible with C5 Configuration <i>PN: Pulsar 320E</i></p> <p>The Pulsar 320E is a high-power, dual output, pulse-only controller geared for overdriving driving lights at very short flash durations with very high current.</p> <p>Output Power: 2500 W Max Pulsed / Output Output Current: 50 A Max Pulsed / Output I/Os: 2 External Trigger Inputs Interface: 10/100 Ethernet with Software GUI. SDKs are also available.</p> <p>For more information about our Pulsar 320E, please visit the controller product page.</p>	
	<p>Inline Controller - Continuous Only - IC Configurations <i>PN: N/A</i></p> <p>The IC is an inline, cable-mounted continuous-only controller configured/wired directly for the ordered light head.</p> <p>Output Power: 25 W Max Continuous Output Current: 1.25 A Max Continuous I/O: 1 0-10 V Analog Dimming Input Interface: Direct Cable (flying leads or optional connector)</p> <p>For more information about our IC Controller please visit the controller product page.</p>	
	<p>Inline Controller - Strobe and Continuous - I3 & I3S Configurations <i>PN: N/A</i></p> <p>The I3 and I3S are inline, cable-mounted continuous and pulse (overdrive strobe) capable controllers configured/wired directly for the ordered light head. When operated in pulsed mode, the I3 is a default-on device on power up, whereas the I3S is default-off, requiring a trigger to illuminate.</p> <p>Output Power: 25 W Max Continuous, 125 W Max Pulsed Output Current: 1.25 A Max Continuous, 8 A Max Pulsed (Load Dependent) I/Os: 1 Gated Trigger Signal, 1 0-10 V Analog Dimming Input Interface: Direct Cable (flying leads or optional connector)</p> <p>For more information about our I3/I3S Controller, please visit the controller product page.</p>	
	<p>Inline Controller - Strobe and Continuous - I4 Configurations <i>PN: N/A</i></p> <p>The I4 is an inline, cable-mounted continuous and pulse (overdrive strobe) capable controller configured/wired directly for the ordered light head. The I4 can either be operated with a PNP or NPN trigger signal.</p> <p>Output Power: 50 W Max Continuous, 150 W Max Pulsed Output Current: 2.1 A Max Continuous, 8 A Max Pulsed (Load Dependent) I/Os: 1 Gated Trigger Signal, 1 0-10 V Analog Dimming Input Interface: Direct Cable (flying leads or optional connector)</p> <p>For more information about our IC Controller please visit the controller product page.</p>	

Electrical Information - Continued

Inline Control Option Wiring Information

Standard Flying Lead and Optional M12 Connector Pinout Functions

Pin (M12)	Wire Color	24V Functions	IC Functions	I3/I3S Functions	I4 Functions	M12 Pinout
1	BROWN	24V DC	24V DC	24V DC	24 V DC	 <p>5-Position Male Connector</p>
2	WHITE	N/A	0-10V Analog Control	Reserved	NPN/Active Low Trigger	
3	BLUE	DC GND	DC GND	DC GND	DC GND	
4	BLACK	N/A	Gate Low	PNP/Active High Trigger	PNP/Active High Trigger	
5	GRAY	N/A	N/A	0-10V Analog Control	0-10 V Analog Dimming	

The functions above are only applicable when ordering an 24, IC, I3, I3s, or I4 power configuration with our without an M12 connector. For more wiring information pertaining to strobing and dimming functionality, please download the controller manuals and datasheets.

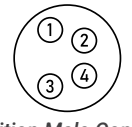

Optional M8 Connector Pinout Functions

Pin (M8)	Wire Color	24V Functions	IC Functions	I3/I3S Functions	I4 Functions	M8 Pinout
1	BROWN	24V DC	24V DC	24V DC	24 V DC	 <p>4-Position Male Connector</p>
2	WHITE	N/A	0-10V Analog Control	Reserved	Active Low Trigger	
3	BLUE	DC GND	DC GND	DC GND	DC GND	
4	BLACK	N/A	Gate Low	Active High Trigger	Active High Trigger	





The functions above are only applicable when ordering an 24, IC, I3, I3s, or I4 power configuration with our without an M8 connector. For more wiring information pertaining to strobing and dimming functionality, please download the controller manuals and datasheets.

Accessories

Advanced Illumination offers a variety of accessories designed to pair with our lighting and control products. Below you will find a table of accessories which are compatible with many configurations of the FX2 Series.

Category	Accessory Image	Accessory Detail
Power Supply		<p>24 Volt DC Power Supply PN: PS24-TL</p> <p>This convenient power source is a universal AC input switching power supply with a regulated output DC current. The power supply comes with an LED Power Indicator, tinned leads marked Positive (+) and Negative (-) and 2 WAGO connectors for simplified assembly.</p> <p>For more information about our 24 Volt DC Power Supply, please visit this webpage.</p>
Dimmer		<p>Manual Dimming Accessory for the IC, I3 and I3s PN: DCS-MP</p> <p>The DCS-MP is a 30-position potentiometer, detented for precision level control and provides repeatable dimming with cable inline controllers. Features include DIN-rail mountable, a flip up cover to prevent accidental adjustments, spring clamp wiring terminal for flying leads or an M12 connector for use with the IC or I3/I3S Inline Controllers.</p> <p>For more information about our Manual Dimming Accessory please visit this webpage.</p>

Electrical Information - Continued

Category	Accessory Image	Accessory Detail
Dimmer		<p>Manual Dimming Accessory for the IC PN: MP-ICS</p> <p>The MP-ICS is a dimmer which is designed for use on lights with the IC Inline Controller. This unit provides for 0 – 100% intensity control. It is NOT COMPATIBLE with LLI37, BLI38, LLI67, and BLI68 "IC" Lights or lights built with the "24v controller" option.</p> <p>For more information about our Manual Dimming Accessory, please visit this webpage.</p>
Extension Cable		<p>Pulsar 320E Extension Cable - C5 Configuration PN: LC-XX-S-C5</p> <p>This extension cable was designed for applications requiring power cables longer than the standard 2 meters provided with Ai lights. This single light cable features a single male and single female Pulsar 320 connector (C5) and can be purchased in 3 - 15 meter lengths.</p> <p>For more information about our Pulsar 320E Extension Cable, please visit this webpage.</p>
Adaptor Cable		<p>Cognex Gen2 Inline Controller Adaptor Cable PN: AD-I3-CGX2</p> <p>This cable adaptor is for connecting I3/I3S configured lights with Cognex Gen2 Cameras, and comes with a male to female M12 connectors.</p> <p>For more information about our Cognex Gen2 Inline Controller Adaptor Cable, please visit this webpage.</p>
Filters		<p>Camera Lens Band Pass Filters PN: BPXXX-YYY</p> <p>Eliminating all but a narrow band of light (+/- 40nm) centered on the specified wavelength, band pass filters are used to enhance colors, or to stop unwanted ambient light from reaching the camera. Filtering can replace existing shrouds, simplifying the physical set up of an inspection site. Ai offers 635nm and 660nm band pass filters to fit several different lens sizes.</p> <p>For more information about our Camera Lens Band Pass Filters, please visit this webpage.</p>
Mounting Brackets		<p>Mounting Brackets PN: LB112</p> <p>Fastens to the M6 mounting channel for simplified mounting. Included in product purchase.</p> <p>For more information about our Mounting Brackets, please visit this webpage.</p>

Additional Information

Warranty

Every Advanced illumination, Inc. (Ai) product is thoroughly inspected and tested before leaving the factory. Products are warranted to be free of defects in workmanship and materials for a period of FIVE YEARS from the original date of purchase. Should a defect develop during this period, customers may return the complete product, freight prepaid, to one of Ai's distributors or to the Ai factory. All product warranty returns require a Return Merchandise Authorization (RMA) number which is obtained from Customer Service. The RMA number must be clearly marked on the outside of the package. Ai will inspect the unit, and if a defect is found will, at our option, repair or replace the product without charge. Ai disclaims liability for any implied warranties, including implied warranties of "merchantability" and "fitness for a specific purpose." For products under warranty that have since been discontinued, Ai will make an effort to replace with equivalent parts; for circumstances that do not allow for equivalent replacement, Ai reserves the right to repair or replace these products with an updated version. Ai cannot be held responsible for the unauthorized or inappropriate use of its products. Any unauthorized repair or modifications will result in a voided warranty. No Liability for Consequential Damages: In no event shall Ai be liable for any consequential, special, incidental, or indirect damages of any kind arising from the sale or use of the products.

Compliance

Our lighting products are designed and tested to meet CE, RoHS, and IEC standards. As a global ISO 9001 certified company, we understand the importance of compliance and perform accelerated testing on every product before shipment. For more information on our compliance standards, please see our compliance documentation here: <https://www.advancedillumination.com/services/compliance-statements/>

Electromagnetic Compatibility

This product was tested and complies with the regulatory requirements and limits for electromagnetic compatibility (EMC) as stated in the product specifications. These requirements and limits are designed to provide reasonable protection against harmful interference only when the product is operated in its intended industrial electromagnetic environment. To minimize the potential for electromagnetic interference or unacceptable performance degradation, install and use this product in strict accordance with the instructions in the product documentation.

Customer Service

For information on existing orders, or to make an order adjustment, contact us Monday through Friday 8:00 am to 5:00 pm ET or send an email to orders@advancedillumination.com.

Company Information

Advanced Illumination
440 State Garage Road, Rochester, VT 05767
Phone: +1 (802) 767 3830
Fax: +1 (802) 767 2636
Email: info@advancedillumination.com
Web: advancedillumination.com
© 2026 Advanced illumination Inc. All rights reserved